

2.4.3. TARGA K1008-AM

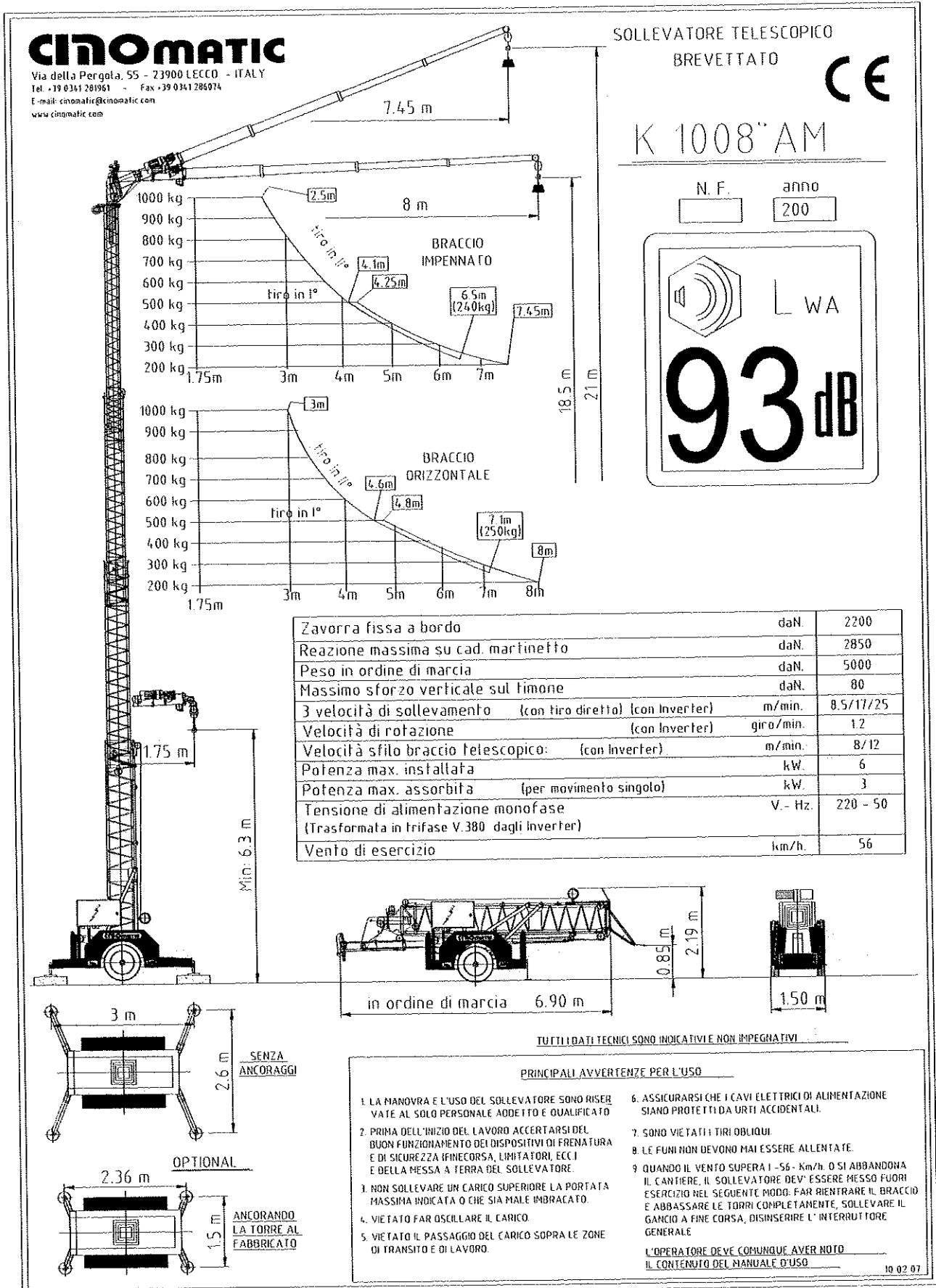

Figura 3